

Dwellings

Card 001
 Number of Stories 1
 Style Conventional
 Year Built 1955
 Year Remodeled 0
 Rooms 5
 Bedrooms 3
 Full Baths 1
 Half Baths 1
 Family Rooms 0
 Dining Rooms 0
 Basement Garages 0
 Condition Average
 Fireplace Stacks 0

Exterior Wall Frame/Siding
 Heating Base
 Cooling Central
 Basement Crawl
 Attic None
 Finished Living Area 1404
 First Floor Area 1404
 Upper Floor Area 0
 Half Floor Area 0
 Finished Basement Area 0
 Total Basement Area 0
 Attic Area 0
 Fireplace Openings 0

Additions

Card 1

Addition Code	Description	Base Area	Year Built
PR2	Porch Frame - Enclosed	264	0
ST1	Stoop Masonry	30	0
PR1	Porch Frame - Open	12	0
GR1	Garage Frame	264	0
GR1	Garage Frame	240	0
PT1	Patio Concrete	320	0

Improvements

Card 1

Improvement Code	Description	Length	Width	Total Area	Year Built	Appraised Value (100%)
1	Garage Frame	24	12	288	1972	\$2,200
60	Shed Utility	16	12	192	1988	\$2,010
Total						\$4,210

Sales

Sale Date	Sale Price	Seller	Buyer	No. Of Properties	Land Only Sale	Deed Type	Conveyance Number
4/6/2018	\$90,000	STAHL-GROVES KATHY J & STAHL KENNITH A & MICHAEL D	BORSOS MICHAEL M JR & BORSOS LISA	1	N	Survivorship Deed	574
12/28/2016	\$0	STAHL-GROVES KATHY J SUCCESSOR TRUSTEE	STAHL-GROVES KATHY J & STAHL KENNITH A & MICHAEL D	1	N	Quit Claim Deed Ex	
12/28/2016	\$0	STAHL NEALY D TRUSTEE LE @(4)	STAHL-GROVES KATHY J SUCCESSOR TRUSTEE	1	N	Affidavit EX	
9/13/1999	\$0	STAHL KENNETH A RMDR	STAHL-GROVES KATHY J RMDR	1	N		1266
9/13/1999	\$0	STAHL-GROVES KATHY J RMDR	STAHL NEALY D TRUSTEE LE	1	N		1266
9/13/1999	\$0	STAHL MICHAEL D RMDR	STAHL KENNETH A RMDR	1	N		1266
9/13/1999	\$0	STAHL NEALY D & MARILYN J TRUSTEE	STAHL MICHAEL D RMDR	1	N		1266
9/30/1994	\$0	STAHL NEALY	STAHL NEALY D & MARILYN J TRUSTEE	1	N		1332
1/1/1990	\$0		STAHL NEALY	0	Y		0

Recent Sales In Area

Sale date range:

From: 04/18/2020

To: 04/18/2023

Sales by Neighborhood

1500

Feet



Sales by Distance

Tax History

Delinquent payments made after the fall due date will still show due in the year they were originally assessed. If paid, payment will show in the next tax year.

Detail: Tax Year	Type	Category	Description	Amount
2022 Pay 2023	Property Tax Detail	Tax	1st half tax	\$835.78
2022 Pay 2023	Special Assessment Detail	Fee	LIGHTING BRADNER 1st half SPA fee	\$0.30
2022 Pay 2023	Special Assessment Detail	Fee	TREE MAINT BRADNER 1st half SPA fee	\$0.08
2022 Pay 2023	Special Assessment Detail	Tax	DH 2406 M BRADNER VIL 1st half tax	\$6.40
2022 Pay 2023	Special Assessment Detail	Tax	LIGHTING BRADNER 1st half tax	\$29.89
2022 Pay 2023	Special Assessment Detail	Tax	TREE MAINT BRADNER 1st half tax	\$7.80
2022 Pay 2023	Property Tax Detail	Tax	2nd half tax	\$835.78
2022 Pay 2023	Special Assessment Detail	Fee	LIGHTING BRADNER 2nd half SPA fee	\$0.30
2022 Pay 2023	Special Assessment Detail	Fee	TREE MAINT BRADNER 2nd half SPA fee	\$0.08
2022 Pay 2023	Special Assessment Detail	Tax	DH 2406 M BRADNER VIL 2nd half tax	\$6.39
2022 Pay 2023	Special Assessment Detail	Tax	LIGHTING BRADNER 2nd half tax	\$29.88
2022 Pay 2023	Special Assessment Detail	Tax	TREE MAINT BRADNER 2nd half tax	\$7.79
2021 Pay 2022	Property Tax Detail	Tax	1st half tax	\$829.05
2021 Pay 2022	Special Assessment Detail	Fee	LIGHTING BRADNER 1st half SPA fee	\$0.30
2021 Pay 2022	Special Assessment Detail	Fee	TREE MAINT BRADNER 1st half SPA fee	\$0.08
2021 Pay 2022	Special Assessment Detail	Tax	DH 2406 M BRADNER VIL 1st half tax	\$6.40
2021 Pay 2022	Special Assessment Detail	Tax	LIGHTING BRADNER 1st half tax	\$30.11
2021 Pay 2022	Special Assessment Detail	Tax	TREE MAINT BRADNER 1st half tax	\$7.86
2021 Pay 2022	Property Tax Detail	Tax	2nd half tax	\$829.05
2021 Pay 2022	Special Assessment Detail	Fee	LIGHTING BRADNER 2nd half SPA fee	\$0.30
2021 Pay 2022	Special Assessment Detail	Fee	TREE MAINT BRADNER 2nd half SPA fee	\$0.08
2021 Pay 2022	Special Assessment Detail	Tax	DH 2406 M BRADNER VIL 2nd half tax	\$6.39
2021 Pay 2022	Special Assessment Detail	Tax	LIGHTING BRADNER 2nd half tax	\$30.11
2021 Pay 2022	Special Assessment Detail	Tax	TREE MAINT BRADNER 2nd half tax	\$7.85
2020 Pay 2021	Property Tax Detail	Tax	1st half tax	\$830.72
2020 Pay 2021	Special Assessment Detail	Fee	LIGHTING BRADNER 1st half SPA fee	\$0.31
2020 Pay 2021	Special Assessment Detail	Fee	TREE MAINT BRADNER 1st half SPA fee	\$0.08
2020 Pay 2021	Special Assessment Detail	Tax	DH 2406 M BRADNER VIL 1st half tax	\$6.40
2020 Pay 2021	Special Assessment Detail	Tax	LIGHTING BRADNER 1st half tax	\$30.60
2020 Pay 2021	Special Assessment Detail	Tax	TREE MAINT BRADNER 1st half tax	\$8.00
2020 Pay 2021	Property Tax Detail	Tax	2nd half tax	\$830.72
2020 Pay 2021	Special Assessment Detail	Fee	LIGHTING BRADNER 2nd half SPA fee	\$0.31
2020 Pay 2021	Special Assessment Detail	Fee	TREE MAINT BRADNER 2nd half SPA fee	\$0.08

Tax Year	Type	Category	Description	Amount
2020 Pay 2021	Special Assessment Detail	Tax	DH 2406 M BRADNER VIL 2nd half tax	\$6.39
2020 Pay 2021	Special Assessment Detail	Tax	LIGHTING BRADNER 2nd half tax	\$30.59
2020 Pay 2021	Special Assessment Detail	Tax	TREE MAINT BRADNER 2nd half tax	\$7.99
2019 Pay 2020	Property Tax Detail	Tax	1st half tax	\$767.18
2019 Pay 2020	Special Assessment Detail	Fee	LIGHTING BRADNER 1st half SPA fee	\$0.30
2019 Pay 2020	Special Assessment Detail	Fee	TREE MAINT BRADNER 1st half SPA fee	\$0.08
2019 Pay 2020	Special Assessment Detail	Tax	DH 2406 M BRADNER VIL 1st half tax	\$0.00
2019 Pay 2020	Special Assessment Detail	Tax	LIGHTING BRADNER 1st half tax	\$30.46
2019 Pay 2020	Special Assessment Detail	Tax	TREE MAINT BRADNER 1st half tax	\$7.96
2019 Pay 2020	Property Tax Detail	Tax	2nd half tax	\$767.18
2019 Pay 2020	Special Assessment Detail	Fee	LIGHTING BRADNER 2nd half SPA fee	\$0.30
2019 Pay 2020	Special Assessment Detail	Fee	TREE MAINT BRADNER 2nd half SPA fee	\$0.08
2019 Pay 2020	Special Assessment Detail	Tax	LIGHTING BRADNER 2nd half tax	\$30.45
2019 Pay 2020	Special Assessment Detail	Tax	TREE MAINT BRADNER 2nd half tax	\$7.95
2018 Pay 2019	Property Tax Detail	Tax	1st half tax	\$770.34
2018 Pay 2019	Special Assessment Detail	Fee	LIGHTING BRADNER 1st half SPA fee	\$0.31
2018 Pay 2019	Special Assessment Detail	Fee	TREE MAINT BRADNER 1st half SPA fee	\$0.08
2018 Pay 2019	Special Assessment Detail	Tax	DH 2406 M BRADNER VIL 1st half tax	\$0.00
2018 Pay 2019	Special Assessment Detail	Tax	LIGHTING BRADNER 1st half tax	\$30.65
2018 Pay 2019	Special Assessment Detail	Tax	TREE MAINT BRADNER 1st half tax	\$8.01
2018 Pay 2019	Property Tax Detail	Tax	2nd half tax	\$770.34
2018 Pay 2019	Special Assessment Detail	Fee	LIGHTING BRADNER 2nd half SPA fee	\$0.31
2018 Pay 2019	Special Assessment Detail	Fee	TREE MAINT BRADNER 2nd half SPA fee	\$0.08
2018 Pay 2019	Special Assessment Detail	Tax	LIGHTING BRADNER 2nd half tax	\$30.64
2018 Pay 2019	Special Assessment Detail	Tax	TREE MAINT BRADNER 2nd half tax	\$8.01

Total:

Tax Year	Amount
2022 Pay 2023	\$1,760.47
2021 Pay 2022	\$1,747.58
2020 Pay 2021	\$1,752.19
2019 Pay 2020	\$1,611.94
2018 Pay 2019	\$1,618.77

Treasurer's Tax Bill

To receive more information on a specific area of the tax bill please [click here](#).

Tax Bill

Click Here to View Tax Details on the Treasurer's Site

Payments

Detail:

Tax Year	Payment Date	Paid By	Amount
2022 Pay 2023	2/13/2023	CORELOGICACH	\$880.25

Tax Year	Payment Date	Paid By	Amount
2021 Pay 2022	7/5/2022	achcorelogic	\$873.78
2021 Pay 2022	2/9/2022	CORELOGIC	\$873.80
2020 Pay 2021	7/6/2021	ACHCORELOGIC	\$876.08
2020 Pay 2021	2/5/2021	ACH CORELOGIC	\$876.11
2019 Pay 2020	7/6/2020	ACHCORELOGIC2	\$805.96
2019 Pay 2020	2/6/2020	CORELOGIC	\$805.98
2018 Pay 2019	6/26/2019	corelogic	\$809.38
2018 Pay 2019	2/7/2019	corelogic36	\$809.39

Total:

Tax Year	Amount
2022 Pay 2023	\$880.25
2021 Pay 2022	\$1,747.58
2020 Pay 2021	\$1,752.19
2019 Pay 2020	\$1,611.94
2018 Pay 2019	\$1,618.77

Sketches

8

7

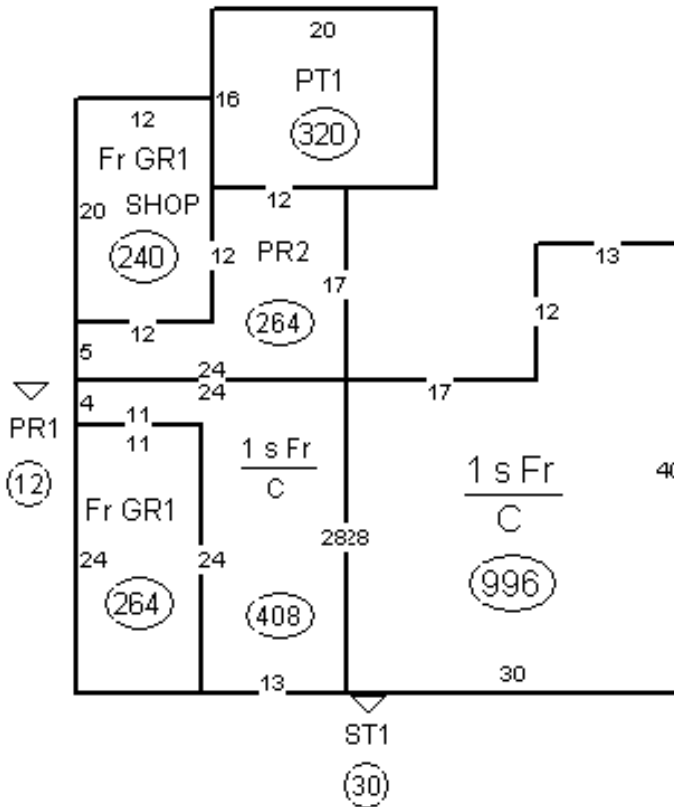

Applications

- [Homestead Exemption Application \(Senior Citizens\) DTE 105A](#)
- [Homestead Exemption Application \(Disabled Veterans\) DTE 105I](#)
- [Owner Occupancy Application 105C](#)

Map



No data available for the following modules: Ag Soil, Buildings.

The information provided by Wood County is provided 'as is' and for reference only. The user expressly agrees that the use of Wood County's web site is at the user's sole risk. Wood County does not warrant that the service will be uninterrupted or error free. Any information published on this server could contain technical inaccuracies or typographical errors. Changes may be made periodically to the tax laws, administrative rules, tax releases and similar materials;

[User Privacy Policy](#)
[GDPR Privacy Notice](#)

[Last Data Upload: 4/18/2023, 6:33:23 AM](#)

Developed by
 Schneider
GEOSPATIAL

Version 3.1.2